

# **SABER SPOT RGBL**

**User Manual**

©2024 ADJ Products, LLC all rights reserved. Information, specifications, diagrams, images, and instructions herein are subject to change without notice. ADJ Products, LLC logo and identifying product names and numbers herein are trademarks of ADJ Products, LLC. Copyright protection claimed includes all forms and matters of copyrightable materials and information now allowed by statutory or judicial law or hereinafter granted. Product names used in this document may be trademarks or registered trademarks of their respective companies and are hereby acknowledged. All non-ADJ Products, LLC brands and product names are trademarks or registered trademarks of their respective companies.

**ADJ Products, LLC** and all affiliated companies hereby disclaim any and all liabilities for property, equipment, building, and electrical damages, injuries to any persons, and direct or indirect economic loss associated with the use or reliance of any information contained within this document, and/or as a result of the improper, unsafe, insufficient and negligent assembly, installation, rigging, and operation of this product.

Europe Energy Saving Notice

Energy Saving Matters (EuP 2009/125/EC)

Saving electric energy is a key to help protecting the environment. Please turn off all electrical products when they are not in use. To avoid power consumption in idle mode, disconnect all electrical equipment from power when not in use. Thank you!

**DOCUMENT VERSION**



Due to additional product features and/or enhancements, an updated version of this document may be available online.

Please check [www.adj.com](http://www.adj.com) for the latest revision/update of this manual before beginning installation and/or programming.

Date	Document Version	Software Version	DMX Channels	Notes
02/01/2024	1.0	1.01	3 / 4-RGBL / 4-HSI / 5 / 6 / 7 / 8-RGBL / 8-16bit / 10 / 12 / 13 Ch	Initial release

# CONTENTS

<b>Introduction</b>	<b>4</b>
<b>Limited Warranty (USA Only)</b>	<b>5</b>
<b>Warranty Registration   Features</b>	<b>6</b>
<b>Safety Precautions</b>	<b>7</b>
<b>Overview</b>	<b>8</b>
<b>Installation Guidelines</b>	<b>9</b>
<b>Accessory Installation</b>	<b>14</b>
<b>Remote Device Management (RDM)</b>	<b>15</b>
<b>Control Panel</b>	<b>16</b>
<b>System Menu</b>	<b>17</b>
<b>DMX Set Up</b>	<b>19</b>
<b>DMX Traits</b>	<b>21</b>
<b>Color Macros Chart</b>	<b>23</b>
<b>Dim Modes</b>	<b>25</b>
<b>Primary-Secondary Set Up   Multi Unit Power Linking</b>	<b>26</b>
<b>Maintenance Guidelines</b>	<b>27</b>
<b>Dimensional Drawings</b>	<b>28</b>
<b>Specifications</b>	<b>29</b>

# INTRODUCTION

**Unpacking:** Thank you for purchasing the Saber Spot RGBL by ADJ Products, LLC. Every device has been thoroughly tested and has been shipped in perfect operating condition. Carefully check the shipping carton for damage that may have occurred during shipping. If the carton appears to have been damaged, carefully inspect your fixture for any damage and be sure all accessories necessary to operate the unit have arrived intact. In the event that damage has been found or parts are missing, please contact our toll free customer support number for further instructions. Do not return this unit to your dealer without first contacting customer support.

**Introduction:** The ADJ Saber Spot RGBL is ADJ Lighting's next generation LED pinspot with a 20-Watt RGBL LED source, ACL lens for a tight 5.7-degree beam, is DMX and RDM compliant and features built-in color macros, color changing programs and has white color temperature presets ranging from 2000K to 9900K. **This product is intended to be used by professionally trained personnel only and is not suitable for private use.**

**Customer Support:** Contact ADJ Service for any product related service and support needs. Also visit [forums.adj.com](http://forums.adj.com) with questions, comments or suggestions.

**Parts:** To purchase parts online visit:

<http://parts.adj.com> (US)

<http://www.adjparts.eu> (EU)

**ADJ SERVICE USA - Monday - Friday 8:00am to 4:30pm PST**

**Voice: 800-322-6337 | Fax: 323-582-2941 | [support@adj.com](mailto:support@adj.com)**

**ADJ SERVICE EUROPE - Monday - Friday 08:30 to 17:00 CET**

**Voice: +31 45 546 85 60 | Fax: +31 45 546 85 96 | [support@adj.eu](mailto:support@adj.eu)**

## **ADJ PRODUCTS LLC USA**

6122 S. Eastern Ave. Los Angeles, CA. 90040

323-582-2650 | Fax 323-532-2941 | [www.adj.com](http://www.adj.com) | [info@adj.com](mailto:info@adj.com)

## **ADJ SUPPLY Europe B.V**

Junostraat 2 6468 EW Kerkrade, The Netherlands

+31 (0)45 546 85 00 | Fax +31 45 546 85 99

[www.adj.eu](http://www.adj.eu) | [info@adj.eu](mailto:info@adj.eu)

## **ADJ PRODUCTS GROUP Mexico**

AV Santa Ana 30 Parque Industrial Lerma, Lerma, Mexico 52000

+52 (728) 282-7070

**Warning!** This unit is intended for indoor use only! Do not expose to rain or moisture!

**CAUTION!** There are no user serviceable parts inside this unit. Do not attempt any repairs yourself, as doing so will void your manufacturer's warranty. In the unlikely event your unit may require service, please contact ADJ Products, LLC.

*Do not discard the shipping carton in the trash. Please recycle when ever possible.*

# LIMITED WARRANTY (USA ONLY)

- A. ADJ Products, LLC hereby warrants, to the original purchaser, ADJ Products, LLC products to be free of manufacturing defects in material and workmanship for a prescribed period from the date of purchase (see specific warranty period on reverse). This warranty shall be valid only if the product is purchased within the United States of America, including possessions and territories. It is the owner's responsibility to establish the date and place of purchase by acceptable evidence, at the time service is sought.
- B. For warranty service, you must obtain a Return Authorization number (RA#) before sending the product back—please contact ADJ Products, LLC Service Department at 800-322-6337. Send the product only to the ADJ Products, LLC factory. All shipping charges must be prepaid. If the requested repairs or service (including parts replacement) are within the terms of this warranty, ADJ Products, LLC will pay return shipping charges only to a designated point within the United States. If the entire instrument is sent, it must be shipped in its original package and packaging material. No accessories should be shipped with the product. If any accessories are shipped with the product, ADJ Products, LLC shall incur no liability whatsoever for loss of or damage to any such accessories, nor for the safe return thereof.
- C. This warranty is void if the product serial number and/or labels are altered or removed; if the product is modified in any manner which ADJ Products, LLC concludes, after inspection, affects the reliability of the product; if the product has been repaired or serviced by anyone other than the ADJ Products, LLC factory unless prior written authorization was issued to purchaser by ADJ Products, LLC; if the product is damaged because it was not properly maintained as set forth in the product instructions, guidelines and/or user manual.
- D. This is not a service contract, and this warranty does not include maintenance, cleaning, or periodic check-up. During the period specified above, ADJ Products, LLC will replace defective parts at its expense with new or refurbished parts, and will absorb all expenses for warranty service and repair labor by reason of defects in material or workmanship. The sole responsibility of ADJ Products, LLC under this warranty shall be limited to the repair of the product, or replacement thereof, including parts, at the sole discretion of ADJ Products, LLC. All products covered by this warranty were manufactured after August 15, 2012, and bear identifying marks to that effect.
- E. ADJ Products, LLC reserves the right to make changes in design and/or improvements upon its products without any obligation to include these changes in any products theretofore manufactured.
- F. No warranty, whether expressed or implied, is given or made with respect to any accessory supplied with products described above. Except to the extent prohibited by applicable law, all implied warranties made by ADJ Products, LLC in connection with this product, including warranties of merchantability or fitness, are limited in duration to the warranty period set forth above. And all warranties, whether expressed or implied, including warranties of merchantability or fitness, are limited in duration to the warranty period set forth above. The consumer's and/or dealer's sole remedy shall be such repair or replacement as is expressly provided above; and under no circumstances shall ADJ Product, LLC be liable for any loss and/or damage, direct and/or consequential arising out of the use of, and/or inability to use this product.
- G. This warranty is the only written warranty applicable to ADJ Products, LLC products, and supersedes all prior warranties and written descriptions of warranty terms and conditions heretofore published.

## MANUFACTURER'S LIMITED WARRANTY PERIODS:

- Non-LED Lighting Products = 1-Year (365 Days) (Including Special Effect Lighting, Intelligent Lighting, UV lighting, Strobes, Fog Machines, Bubble Machines, Mirror Balls, Par Cans, Trussing, Lighting Stands, Power/Data Distribution, etc. excluding LED and lamps)
- Laser Products = 1-Year (365 Days) (excluding laser diodes which have a 6-Month Limited Warranty)
- LED Products = 2-Year (730 Days) (excluding batteries which have a 180 Day Limited Warranty)
- NOTE: 2-Year (730 Days) Limited Warranty ONLY applies to product purchased within the United States. StarTec Series = 1-Year (365 Days) (excluding batteries which have a 180 Day Limited Warranty)
- ADJ DMX Controllers = 2 Year (730 Days)
- American Audio Products = 1 Year (365 Days)

# WARRANTY REGISTRATION

Please fill out the enclosed warranty card to validate your purchase. All returned service items, whether under warranty or not, must be freight pre-paid and accompanied by a return authorization (R.A.) number. The R.A. number must be clearly written on the outside of the return package. A brief description of the problem as well as the R.A. number must also be written down on a piece of paper included in the shipping carton. If the unit is under warranty, you must provide a copy of your proof of purchase invoice. You may obtain an R.A. number by contacting our customer support team. All packages returned to the service department not displaying an R.A. number on the outside of the package will be returned to the shipper.

## FEATURES

- 20 Watt RGBL (Red, Green, Blue, Lime) LED Source
- ACL Lens for Tight 5.7-Degree Beam
- DMX and RDM Compliant
- Built-in Color Macros and Color Changing Programs
- White Color Temperature Presets, 2000K - 9900K

## INCLUDED ITEMS

- 1.83m Indoor Locking Power Cord (x1)
- 10-Degree Frost Filter Lens (x1)
- 45-Degree Frost Filter Lens (x1)
- Metal Clip Ring for Frost Filter Lens (x1)

# SAFETY PRECAUTIONS



**PROTECTION CLASS 1 - FIXTURE MUST BE PROPERLY GROUNDED.**



**THERE ARE NO USER SERVICEABLE PARTS INSIDE THIS UNIT. DO NOT ATTEMPT ANY REPAIRS YOURSELF, AS DOING SO WILL VOID YOUR MANUFACTURER'S WARRANTY. DAMAGES RESULTING FROM MODIFICATIONS TO THIS FIXTURE AND/OR THE DISREGARD OF SAFETY INSTRUCTIONS AND GUIDELINES IN THIS MANUAL VOID THE MANUFACTURER'S WARRANTY AND ARE NOT SUBJECT TO ANY WARRANTY CLAIMS AND/OR REPAIRS.**



**NEVER LOOK DIRECTLY INTO THE LIGHT SOURCE!  
RETINA INJURY RISK - MAY INDUCE BLINDNESS!  
SENSITIVE PERSONS MAY SUFFER AN EPILEPTIC SHOCK!**

- **Maximum ambient operating temperature is 113°F (45°C)!**
- DO NOT TOUCH the fixture housing during operation. Disconnect the power and allow approximately 15 minutes for the fixture to cool down before servicing.
- DO NOT shake the fixture, and avoid brute force when installing and/or operating the fixture.
- DO NOT operate the fixture if the power cord has become frayed, crimped and/or damaged. If the power cord is damaged, replace immediately with a new one of the same power rating.
- DO NOT attempt to remove or break off the ground prong from the electrical cord. This prong is used to reduce the risk of electrical shock and fire in case of an internal short.
- DO NOT attempt to operate this unit if it has been damaged in any way.
- Disconnect from main power before making any type of connection.
- DO NOT block any air ventilation slots. All fan and air inlets must remain clean and never blocked. Allow approx. 6" (15cm) between fixture and other devices or a wall for proper cooling.
- Always be sure to mount this unit in an area that will allow proper ventilation. Allow about 6" (15cm) between this device and a wall.
- This device is intended for indoor use only! Outdoors usage voids all manufacturer's warranties.
- DO NOT remove the cover for any reason.
- When installing fixture in a suspended environment, always use mounting hardware that is no less than M10 x 25mm, and always install fixture with an appropriately rated safety cable.
- Never plug this unit in to a dimmer pack.
- During long periods of non-use, disconnect the unit's main power.
- Always mount this unit in safe and stable matter.
- Power-supply cords should be routed so that they are not likely to be walked on or pinched by items placed upon or against them, paying particular attention to the point where they exit from the unit.
- Cleaning - The fixture should be cleaned only as recommended by the manufacturer.
- Heat - The appliance should be situated away from heat sources such as radiators, heat registers, stoves, or other appliances (including amplifiers) that produce heat.
- The fixture should be serviced by qualified service personnel when:
  - A. The power-supply cord or the plug have been damaged.
  - B. Objects have fallen onto, or liquids have been spilled into, the fixture.
  - C. The fixture does not appear to operate normally or exhibits a marked change in performance.
  - D. The fixture has fallen and/or has been subjected to extreme handling.

# OVERVIEW

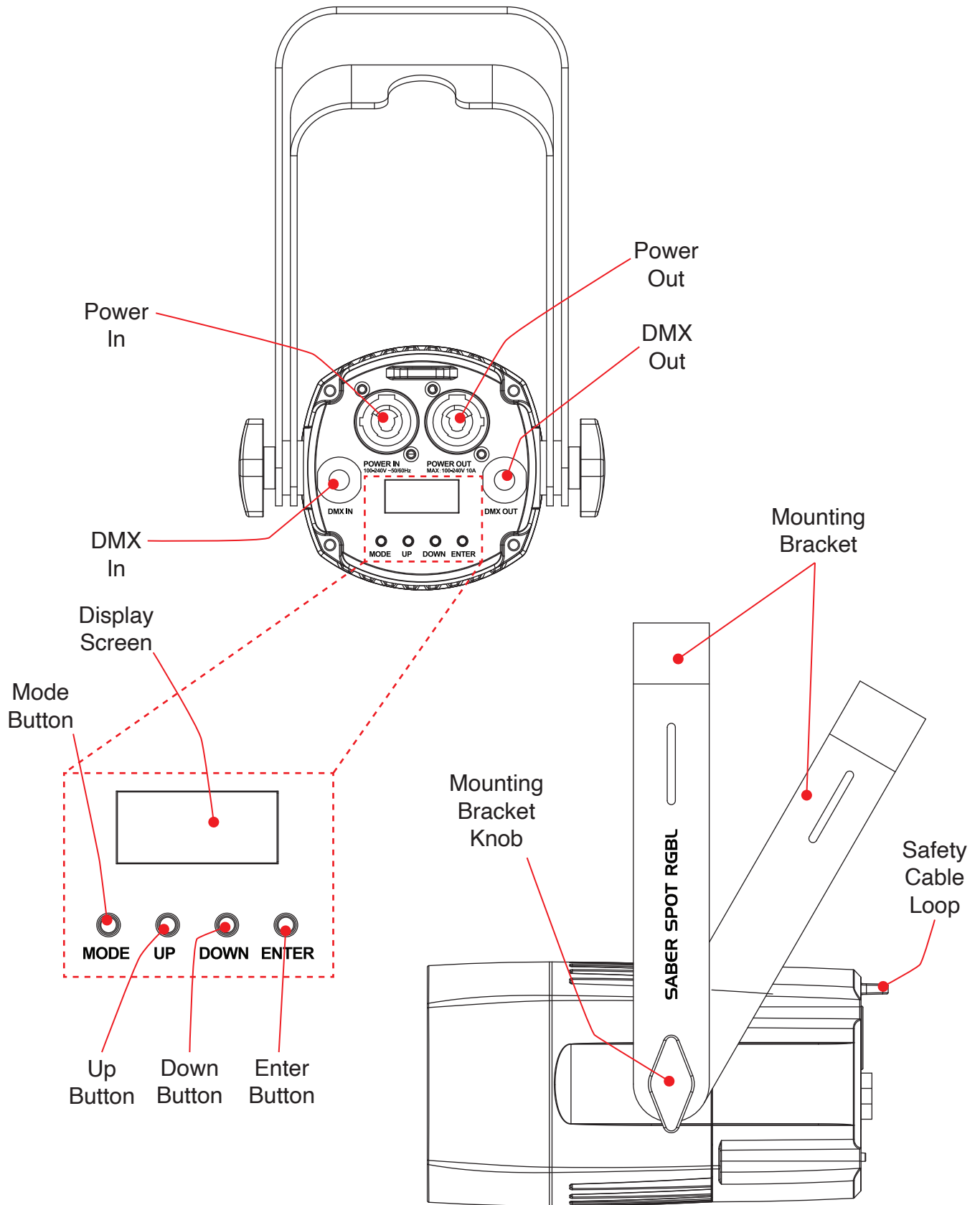



# INSTALLATION GUIDELINES



**DO NOT INSTALL THE FIXTURE IF YOU ARE NOT QUALIFIED TO DO SO!**

Fixture **MUST** be installed following all local, national, and country commercial electrical and construction codes and regulations.

When installing the unit, the trussing or area of installation must be able to hold 10 times the weight of the unit and any attached accessories without any deformation. The unit must be secured with a secondary safety attachment, e.g. an appropriately-rated safety cable.

Before rigging/mounting a single fixture to any metal truss/structure or placing the fixture(s) on any surface, a professional equipment installer **MUST** be consulted to determine if the metal truss/structure or surface is properly certified to safely hold the combined weight of the fixture(s), clamps, cables, and accessories.

Maximum ambient operating temperature is range **113°F (45°C)**. Do not operate this device when ambient temperature exceeds this value!

Fixture(s) should be installed away from walking paths, seating areas, or areas where unauthorized personnel might reach the fixture by hand.

**NEVER** stand directly below the fixture(s) when rigging, removing, or servicing.

Overhead fixture installation must always be secured with a secondary safety attachment, such as an appropriately rated safety cable that can hold 10 times the weight of the fixture.

Overhead mounting requires extensive experience, including calculating working load limits, knowledge of installation material being used, and periodic safety inspection of all installation material as well as the unit itself. If you lack these qualifications, do not attempt the installation yourself.

The installation should be checked by a skilled person once a year.

# INSTALLATION GUIDELINES

## CLAMP MOUNTING

When mounting the fixture to a truss or any other suspended structure, be sure to secure an appropriately rated clamp to the hole on the top of the mounting bracket. Insert a bolt of appropriate size through the bottom of the mounting clamp and the hole on the mounting bracket, and secure them together with a matching nut. Additionally, a safety cable of the appropriate weight rating should be secured through the safety cable loop on the rear of the unit.

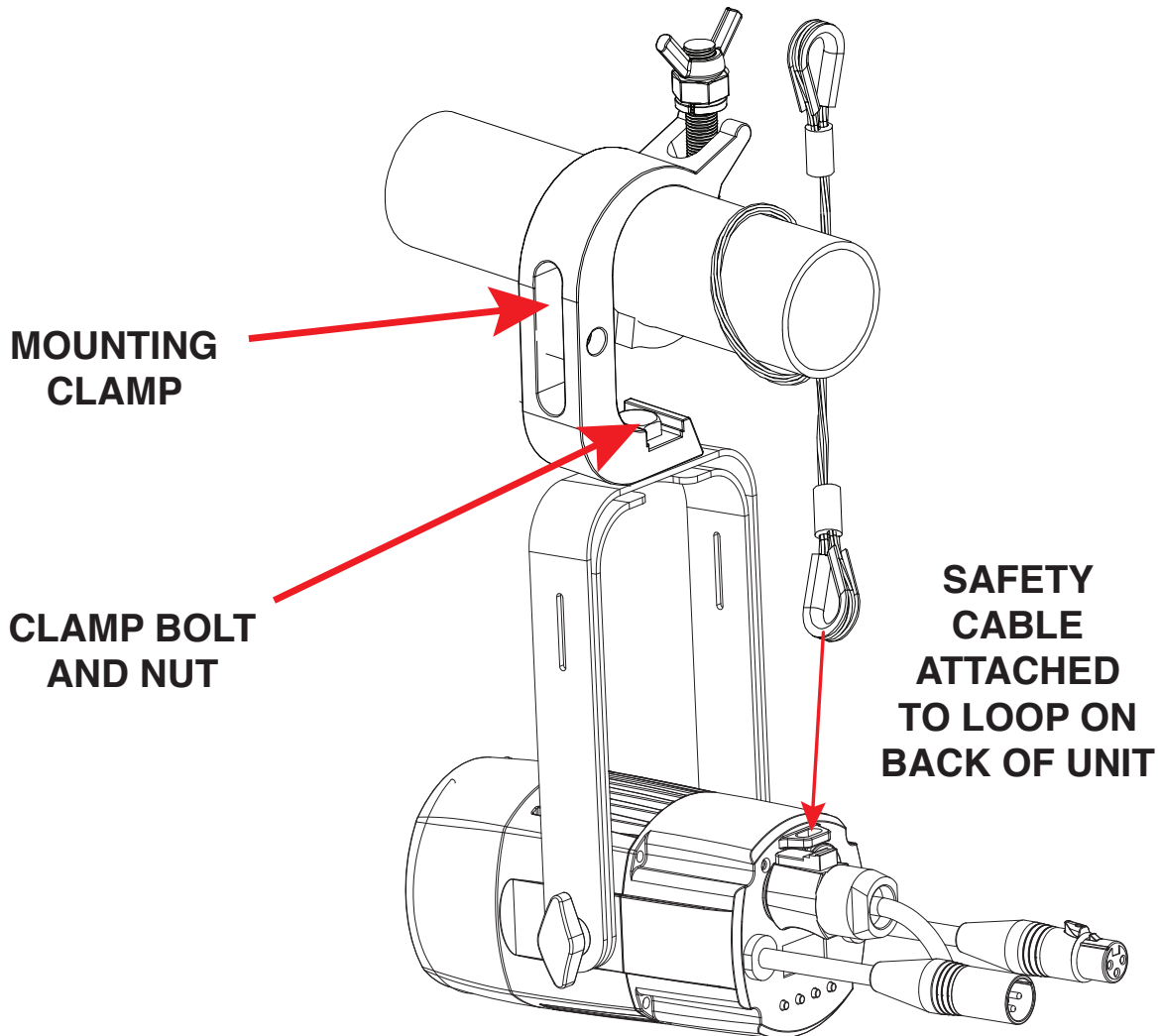

### SAFETY CABLE:

**ALWAYS ATTACH A SAFETY CABLE WHENEVER INSTALLING THIS FIXTURE IN A SUSPENDED ENVIRONMENT TO ENSURE THAT THE FIXTURE WILL NOT FALL IF THE CLAMP FAILS.**

# INSTALLATION GUIDELINES

## STAND MOUNTING

This unit can also be installed atop a tripod stand. Simply secure the Omega bracket to the bottom face of the device, then insert the threaded bolt on the top of the tripod stand through the hole in the Omega bracket. Tighten the nut onto the threaded bolt to secure the mounted device in place.

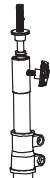
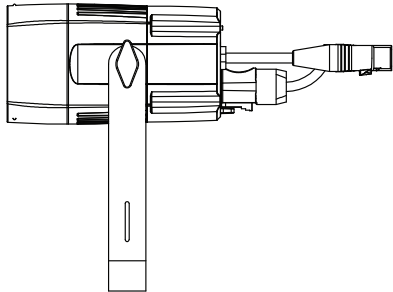

**CAUTION!**

**MAKE SURE THAT THE TRIPOD LEGS AND ALL TELESCOPING ELEMENTS OF THE TRIPOD STAND ARE LOCKED IN PLACE BEFORE INSTALLING THE DEVICE ATOP THE STAND!**

**POSITION THE TRIPOD STAND AND MOUNTED DEVICE ONLY ON FLAT, STABLE SURFACES! DEPLOY TRIPOD LEGS FULLY IN ORDER TO MAXIMIZE STABILITY!**

# INSTALLATION GUIDELINES

## POTENTIAL INTERNAL FIXTURE DAMAGE FROM EXTERNAL SOURCES OF LIGHT BEAMS

External sources of light beams from direct sunlight, lighting moving head fixtures, and lasers, which are focused directly towards the exterior housing and/or penetrate the front lens opening of ADJ lighting fixtures, can cause severe internal damage including burning to optics, dichroic color filters, glass and metal gobos, prisms, animation wheels, frost filters, iris, shutters, motors, belts, wiring, discharge lamps, and LEDs.

This issue is not specific only to ADJ lighting fixtures, it is a common issue with lighting fixtures from all manufacturers. Although there is no true way to fully prevent this issue from happening, the guidelines below can prevent any potential damage from occurring if followed. Contact ADJ Service for more details.

**DO NOT EXPOSE THE FIXTURE AND/OR FRONT LENS OPENING TO LIGHT BEAMS FROM DIRECT SUNLIGHT, OTHER LIGHTING MOVING HEAD FIXTURES, AND LASERS WHILE UNPACKING, INSTALLATION, USE, AND EXTENDED IDLE TIMES OUTDOORS. DO NOT FOCUS A LIGHT BEAM FROM ONE LIGHTING FIXTURE DIRECTLY TOWARDS ANOTHER.**

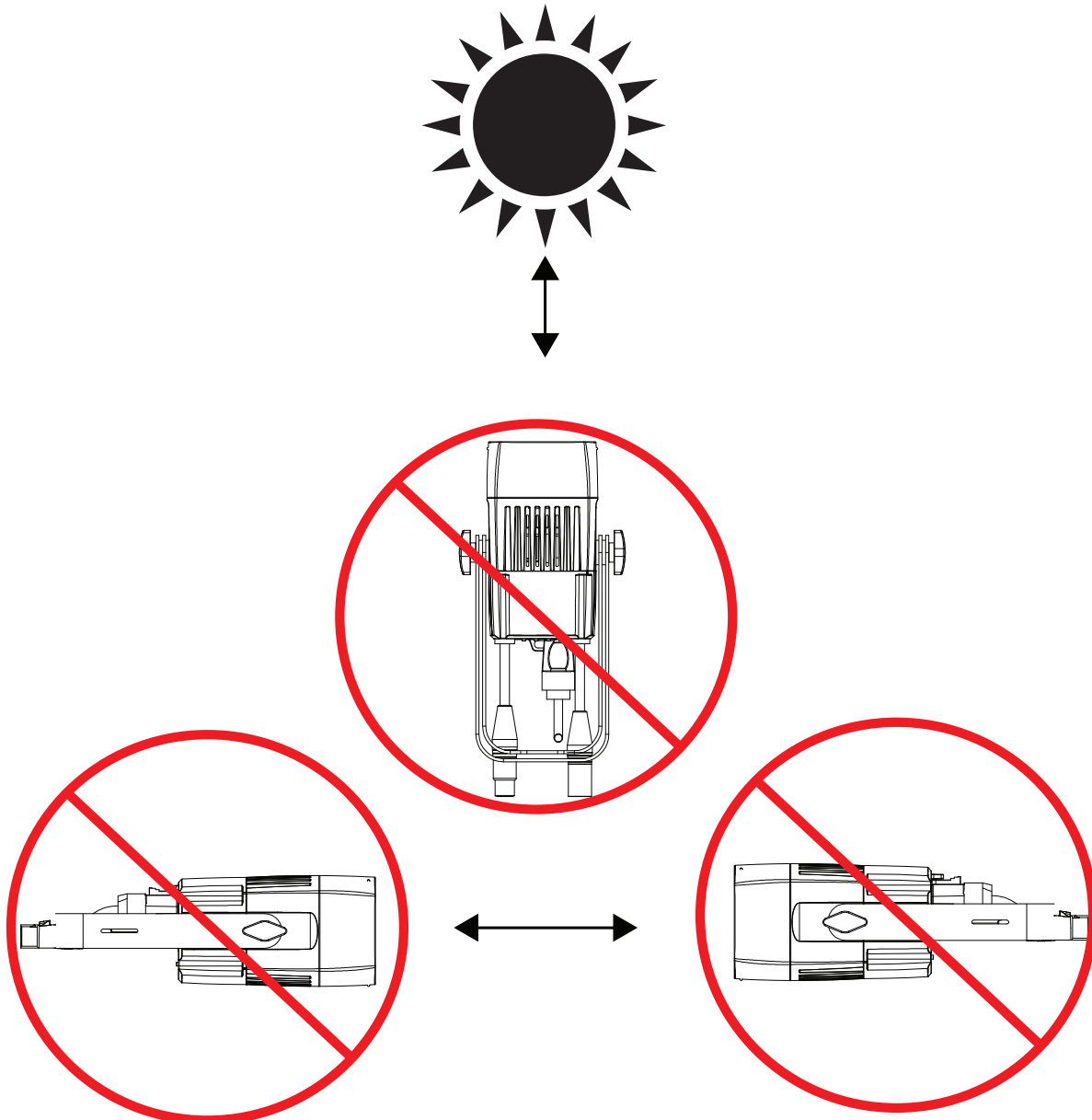

# INSTALLATION GUIDELINES

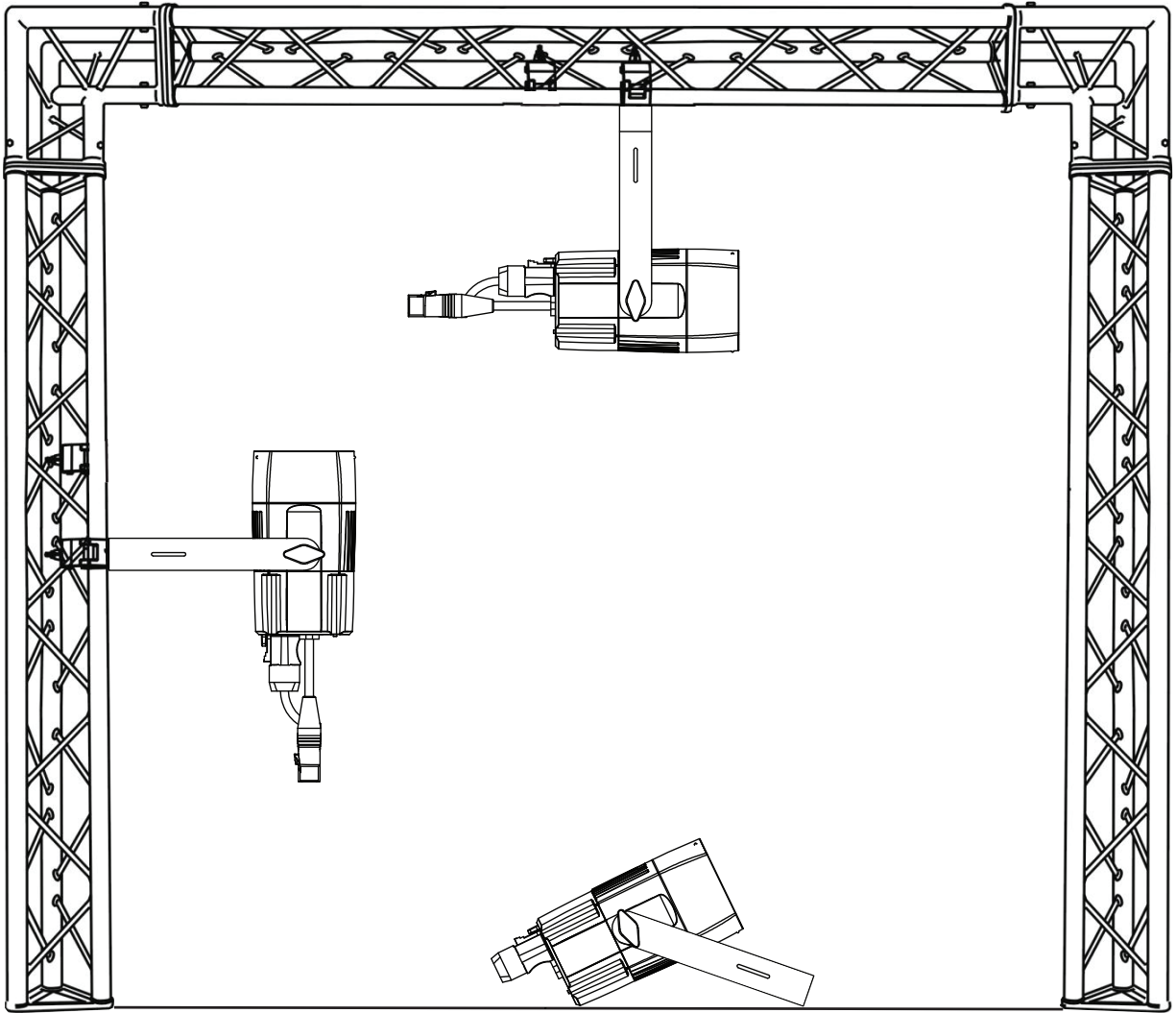

The unit is fully operational in three different mounting positions: hanging upside-down from the ceiling or trussing, sideways on trussing, or set on a flat level surface. Be sure this fixture is kept at least 12m (40ft) away from any flammable materials (decorations, etc). Always use and install a safety cable (not included) as a safety measure to prevent accidental damage and/or injury in the event the clamp fails. Never use the carrying handles for secondary attachment.



**FALLING FIXTURES CAN CAUSE SEVERE INJURY OR SERIOUS EQUIPMENT DAMAGE! FOR THIS REASON, FIXTURES SHOULD BE INSTALLED AND INSPECTED ONLY BY QUALIFIED PERSONNEL. DO NOT INSTALL THE UNIT IF YOU LACK THE QUALIFICATIONS TO DO SO, OR IF YOU HAVE DOUBTS ABOUT THE SAFETY AND SECURITY OF THE INSTALLATION SETUP OR LOCATION!**



**ALWAYS ATTACH A SAFETY CABLE WHENEVER INSTALLING THIS FIXTURE IN A SUSPENDED ENVIRONMENT TO ENSURE THAT THE FIXTURE WILL NOT FALL IF THE CLAMP FAILS.**

# ACCESSORY INSTALLATION

## FROST FILTER

A removeable frost filter is included with the fixture. To install, begin by inserting the frost filter, making sure that the frost filter sits behind the retainer groove. Install the retainer clip by inserting the hooked end of the retainer clip into the retainer groove in the frame of the fixture. Pinch the clip and press into the groove to secure in place. To remove the frost filter, use a precision tool to press on the hooked end of the retainer clip, then pinch the retainer clip and remove from the groove. The frost filter can then be lifted out.

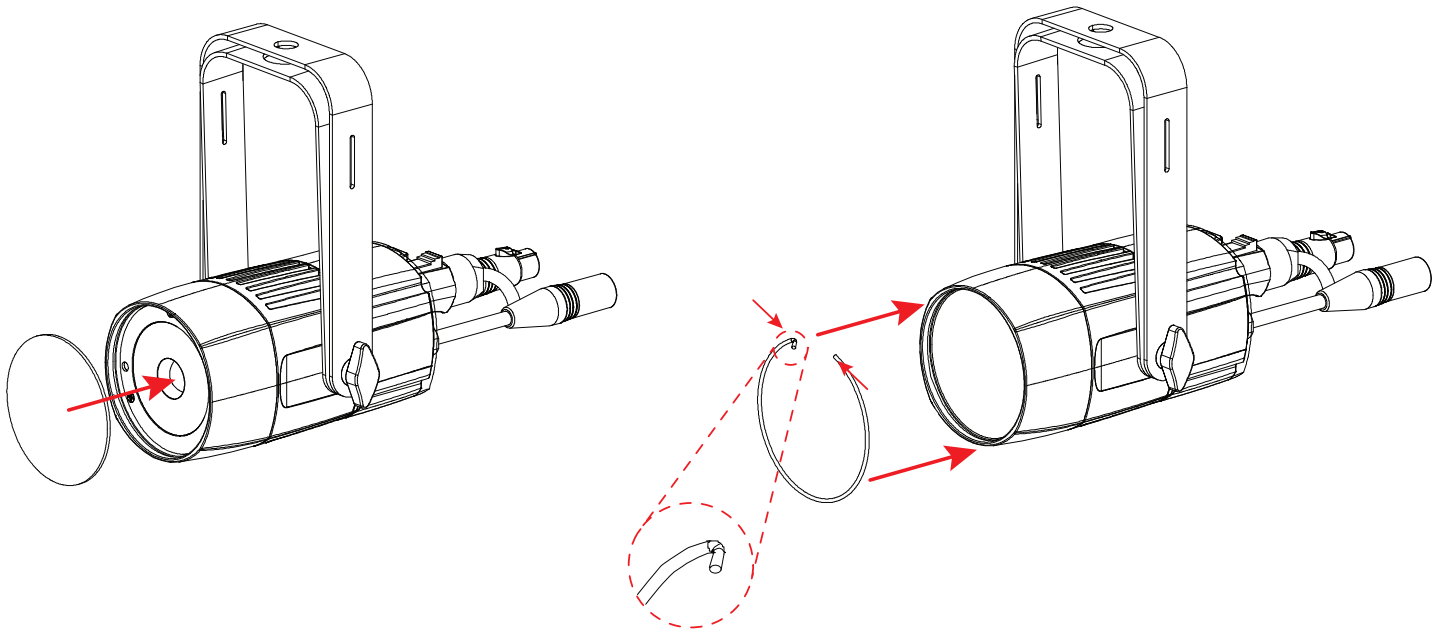

# REMOTE DEVICE MANAGEMENT (RDM)

**NOTE: In order for RDM to work properly, RDM enabled equipment must be used throughout the entire system, including DMX data splitters and wireless systems.**

Remote Device Management (RDM) is a protocol that sits on top of the DMX512 data standard for lighting, allowing the DMX systems of the fixtures to be modified and monitored remotely. This protocol is ideal for instances in which a unit is installed in a location that is not easily accessible.

With RDM, the DMX512 system becomes bi-directional, allowing a compatible RDM enabled controller to send out a signal to devices on the wire, as well as allowing the fixture to respond (known as a *GET* command). The controller can then use its *SET* command to modify settings that would typically have to be changed or viewed directly via the unit's display screen, including the DMX Address, DMX Channel Mode, and Temperature Sensors.

## FIXTURE RDM INFORMATION:

RDM Code	Device ID	Device Model ID	Personality ID
1900	0043 XXXX	0x0043	3ch HSI (001); 4ch RGLr (002); 4ch HSI+ (003); 5ch RGLr (004); 6ch sRGL (005); 6ch RGLr (006); 7ch RGLr (007); 8ch RGLr (008); 8ch 16BIT (009); 10ch HSI (010); 12ch SRGB (011); 13ch RGL (012)

**Please be aware that not all RDM devices support all RDM features**, and therefore it is important to check beforehand to ensure that the equipment that you are considering includes all of the features that you require.

[0x0001] Discovery Unique Branch
[0x0050] Supported Parameters
[0x0060] Device Info
[0x0080] Device Model Description
[0x0081] Manufacturer Label
[0x0082] Device Label
[0x00C0] Software Version Label
[0x00E0] DMX Personality
[0x00E1] DMX Personality Description
[0x00F0] DMX Start Address
[0x0200] Sensor Definition
[0x0201] Sensor Value
[0x0400] Device Hours
[0x1000] Identify Device

# CONTROL PANEL

This unit features a display screen with a 4-button control pad, which can be used to easily adjust any device settings.

Pressing the MODE button will cycle through the various Main Menu options. When the desired Main Menu option is displayed on the screen, press the ENTER button to enter the sub-menu, then use the UP and DOWN buttons to scroll through sub-menu options. In some cases, there will be a second sub-menu that can be navigated in the same way.

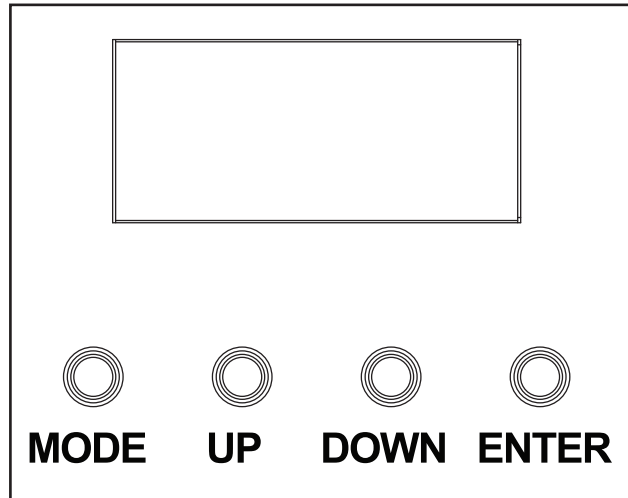

## SCREEN LOCK

The control panel screen will lock after a period of inactivity. To unlock the screen, press and hold the MODE button for 3 seconds. This feature is disabled by default, but it can be enabled or disabled by navigating to the “Autolock” setting in the main system menu.



# SYSTEM MENU

<b>DMX MODE</b>	ADDR: <b>001</b> - 510		Set DMX starting address
<b>CHANNEL</b>	<b>3Ch HSI</b>		Select DMX channel mode
	4Ch RGBL		
	4Ch HSI+		
	5Ch RGBL		
	6Ch sRGBLI		
	6Ch RGBL		
	7Ch RGBL		
	8Ch RGBL		
	8Ch 16Bit		
	10Ch HSI		
	12Ch sRGBLI		
	13Ch RGBL		
<b>SECONDARY</b>	Secondary Mode		Set unit as a secondary unit
<b>LOOK</b>	Store: <b>01</b> - 13		Store mode
<b>RESET</b>	Yes / <b>No</b>		Restore to default factory settings
<b>MANUAL</b>	Rxxx	000 - <b>255</b>	Manual mode red setting
	Gxxx	000 - <b>255</b>	Manual mode green setting
	Bxxx	000 - <b>255</b>	Manual mode blue setting
	Lxxx	000 - <b>255</b>	Manual mode lime setting
	Sxxx	000 - <b>255</b>	Manual mode strobe setting
<b>DIM CURVE</b>	<b>Standard</b>		Select dim curve
	Stage		
	TV		
	Architec		
	Theatre		
<b>NO DMX HOLD</b>	Blackout		Unit takes all parameters to 0 when DMX connection is lost or interrupted
	<b>Hold</b>		Unit holds last received settings when DMX connection is lost or interrupted
	LOOK		Unit default to pre-set LOOK mode program when DMX connection is lost or interrupted
<b>WHITE BL</b>	Rxxx	000 - 255	White balance, red component
	Gxxx	000 - 255	White balance, green component
	Bxxx	000 - 255	White balance, blue component
	Lxxx	000 - 255	White balance, lime component
<b>WHITE CCT BL</b>	Rxxx	000 - 255	Color temperature balance, red component
	Gxxx	000 - 255	Color temperature balance, green component
	Bxxx	000 - 255	Color temperature balance, blue component
	Lxxx	000 - 255	Color temperature balance, lime component

# SYSTEM MENU

<b>TEMP UNIT</b>	<i>C / F</i>	Select temperature units
<b>TEMP VAL</b>	xxx	Display current temperature
<b>AUTOLOCK</b>	<i>Off</i> / On	Control lock after certain period of inactivity
<b>IR ACTIVE</b>	<i>Off</i> / On	Enable or disable IR control
<b>FLIP DISPLAY</b>	<i>Off</i> / On	Invert display orientation

# DMX SET UP

**DMX-512:** DMX is short for Digital Multiplex. This is a universal protocol used as a form of communication between intelligent fixtures and controllers. A DMX controller sends DMX data instructions from the controller to the fixture. DMX data is sent as serial data that travels from fixture to fixture via the DATA “IN” and DATA “OUT” XLR terminals located on all DMX fixtures (most controllers only have a DATA “OUT” terminal).

**DMX Linking:** DMX is a language allowing all makes and models of different manufacturers to be linked together and operate from a single controller, as long as all fixtures and the controller are DMX compliant. To ensure proper DMX data transmission, try to use the shortest cable path possible when linking several DMX fixtures. The order in which fixtures are connected in a DMX line does not influence the DMX addressing. For example, a fixture assigned a DMX address of 1 may be placed anywhere in a DMX line: at the beginning, at the end, or anywhere in the middle. When a fixture is assigned a DMX address of 1, the DMX controller knows to send DATA assigned to address 1 to that unit, no matter where it is located in the DMX chain.

**Data Cable (DMX Cable) Requirements (For DMX Operation):** This unit can be controlled via DMX-512 protocol. The DMX address is set on the rear panel of the unit. Your unit and your DMX controller require a standard 5-pin XLR connector for data input and data output. We recommend Accu-Cable DMX cables. If you are making your own cables, be sure to use standard 110-120 Ohm shielded cable (This cable may be purchased at almost all pro lighting stores). Your cables should be made with a male XLR connector at one end and a female XLR connector at the other. Also remember that DMX cable must be daisy chained and cannot be split.

**Notice:** Be sure to follow the illustration below when making your own cables. Do not use the ground lug on the XLR connector. Do not connect the cable’s shield conductor to the ground lug or allow the shield conductor to come in contact with the XLR’s outer casing. Grounding the shield could cause a short circuit and erratic behavior.

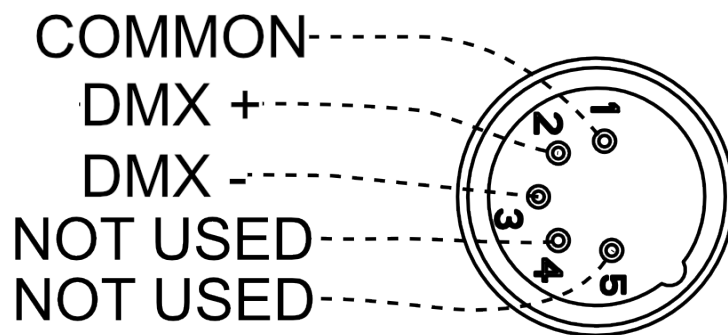

# DMX SET UP

**Special Note: Line Termination.** When longer runs of cable are used, you may need to use a terminator on the last unit to avoid erratic behavior. A terminator is a 110-120 ohm 1/4 watt resistor which is connected between pins 2 and 3 of a male XLR connector (DATA + and DATA -). This unit is inserted in the female XLR connector of the last unit in your daisy chain to terminate the line. Using a cable terminator (ADJ part number Z-DMX/T) will reduce the risk of erratic behavior.

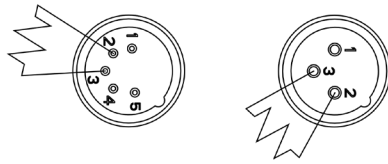

A DMX512 terminator reduces signal errors, avoiding most signal reflection interference. Connect PIN 2 (DMX-) and PIN 3 (DMX+) of the last fixture in series with a 120 Ohm, 1/4 W Resistor to terminate the DMX512.

## DMX ADDRESSING.

All fixtures should be given a DMX starting address when using a DMX controller, so the correct fixture responds to the correct control signal. This digital starting address is the channel number from which the fixture starts to “listen” to the digital control signal sent out from the DMX controller. The assignment of this starting DMX address is achieved by setting the correct DMX address on the digital control display on the fixture.

You can set the same starting address for all fixtures or a group of fixtures, or set different addresses for each individual fixture. Setting all fixtures to the same DMX address will cause all fixtures to react in the same way. In other words, changing the settings of one channel will affect all the fixtures simultaneously.

If you set each fixture to a different DMX address, each unit will start to “listen” to the channel number you have set, based on the quantity of DMX channels of each fixture. That means changing the settings of one channel will only affect the selected fixture.

For example, when this unit is operating in 3 channel mode, you should set the starting DMX address of the first unit to 1, the second unit to 4 (1 + 3), the third unit to 7 (1 + 3 + 3), and so on. See the chart below for more details.

CHANNEL MODE	UNIT 1 ADDRESS	UNIT 2 ADDRESS	UNIT 3 ADDRESS	UNIT 4 ADDRESS
3Ch	1	4	7	10
4Ch RGBL / 4Ch HSI+	1	5	9	13
5Ch	1	6	11	16
6Ch sRGBLI / 6Ch RGBL	1	7	13	19
7Ch	1	8	15	22
8Ch RGBL / 8Ch 16Bit	1	9	17	25
10Ch	1	11	21	31
12Ch	1	13	25	37
13Ch	1	14	27	40

# DMX TRAITS

CHANNEL												DMX VALUES	FUNCTION
3CH	4CH RGBL	4CH HSI+	5CH	6CH sRGB BLI	6CH RGBL	7CH	8CH RGBL	8CH 16bit	10CH	12CH	13CH		
	1		1	2	1	1	1	1		2	1	000 - 255	<b>Red</b> , 0 - 100%
								2				000 - 255	<b>Red Fine</b> , 0 - 100%
	2		2	3	2	2	2	3		3	2	000 - 255	<b>Green</b> , 0 - 100%
								4				000 - 255	<b>Green Fine</b> , 0 - 100%
	3		3	4	3	3	3	5		4	3	000 - 255	<b>Blue</b> , 0 - 100%
								6				000 - 255	<b>Blue Fine</b> , 0 - 100%
	4		4	5	4	4	4	7		5	4	000 - 255	<b>Lime</b> , 0 - 100%
								8				000 - 255	<b>Lime Fine</b> , 0 - 100%
													<b>CCT</b>
												000	Off
									5	7	5	001 - 042	2700K
												043 - 085	3200K
												086 - 128	4000K
												129 - 171	5600K
												172 - 214	6500K
												215 - 255	7000K
									6	8	6	000 - 255	<b>Macros</b> , refer to <b>Color Macro Chart</b> section
				1		5	5		1	1	7	000 - 255	<b>Strobe</b> , 0 - 100%
1		1							2			000 - 255	<b>Hue</b> , 0 - 100%
2		2							3			000 - 255	<b>Saturation</b> , 0 - 100%
			5		5	6	6				8	000 - 255	<b>Dimmer</b> , 0 - 100%
					6	7	7				9	000 - 255	<b>Dimmer Fine</b> , 0 - 100%
3		3		6					4	6		000 - 255	<b>Intensity</b> , 0 - 100%

# DMX TRAITS

CHANNEL												DMX VALUES	FUNCTION				
3CH	4CH RGBL	4CH HSI+	5CH	6CH sRG BLI	6CH RGBL	7CH	8CH RGBL	8CH 16bit	10CH	12CH	13CH						
																	<b>Auto Programs</b>
																	000 Off
																	001 - 020 Auto Program 1
																	021 - 040 Auto Program 2
																	041 - 060 Auto Program 3
																	061 - 080 Auto Program 4
																	081 - 100 Auto Program 5
																	101 - 120 Auto Program 6
										7	9						121 - 140 Auto Program 7
																	141 - 160 Auto Program 8
																	161 - 180 Auto Program 9
																	181 - 200 Auto Program 10
																	201 - 220 Auto Program 11
																	221 - 240 Auto Program 12
																	241 - 250 Auto Program 13
																	251 - 255 Gradient Effect
																	<b>Programs Speed</b> , slow to fast
																	000 - 255
																	<b>Programs Fade</b> , fast to slow
																	000 - 255
																	<b>Dim Modes</b>
																	000 - 020 Standard
																	021 - 040 Stage
																	041 - 060 TV
																	061 - 080 Architectural
																	081 - 100 Theatre
																	101 - 255 Default to Unit Setting

# COLOR MACROS CHART

DMX VALUES	RED	GREEN	BLUE	LIME
000	0	0	0	0
001 - 004	80	255	234	80
005 - 008	80	255	164	80
009 - 012	77	255	112	77
013 - 016	117	255	83	83
017 - 020	160	255	77	77
021 - 024	223	255	83	83
025 - 028	255	243	77	77
029 - 032	255	200	74	74
033 - 036	255	166	77	77
037 - 040	255	125	74	74
041 - 044	255	97	77	74
045 - 048	255	71	77	71
049 - 052	255	83	134	83
053 - 056	255	93	182	93
057 - 060	255	96	236	96
061 - 064	238	93	255	93
065 - 068	196	87	255	87
069 - 072	150	90	255	90
073 - 076	100	77	255	77
077 - 080	77	100	255	77
081 - 084	67	148	255	67
085 - 088	77	195	255	77
089 - 092	77	234	255	77
093 - 096	158	255	144	144
097 - 100	255	251	153	153
101 - 104	255	175	147	147
105 - 108	255	138	186	138
109 - 112	255	147	251	147
113 - 116	151	138	255	138
117 - 120	99	0	255	100
121 - 124	138	169	255	138
125 - 128	255	255	255	255
129 - 132	255	206	143	0
133 - 136	254	177	153	0
137 - 140	254	192	138	0
141 - 144	254	165	98	0
145 - 148	254	121	0	0
149 - 152	176	17	0	0

# COLOR MACROS CHART

DMX VALUE	RED	GREEN	BLUE	LIME
153 - 156	96	0	11	0
157 - 160	234	139	171	0
161 - 164	224	5	97	0
165 - 168	175	77	173	0
169 - 172	119	130	199	0
173 - 176	147	164	212	0
177 - 180	88	2	163	0
181 - 184	0	38	86	0
185 - 188	0	142	208	0
189 - 192	52	148	209	0
193 - 196	1	134	201	0
197 - 200	0	145	212	0
201 - 204	0	121	192	0
205 - 208	0	129	184	0
209 - 212	0	83	115	0
213 - 216	0	97	166	0
217 - 220	1	100	167	0
221 - 224	0	40	86	0
225 - 228	209	219	182	0
229 - 232	42	165	85	0
233 - 236	0	46	35	0
237 - 240	8	107	222	0
241 - 244	255	0	0	0
245 - 248	0	255	0	0
249 - 252	0	0	255	0
253 - 255	0	0	0	255



# DIM MODES

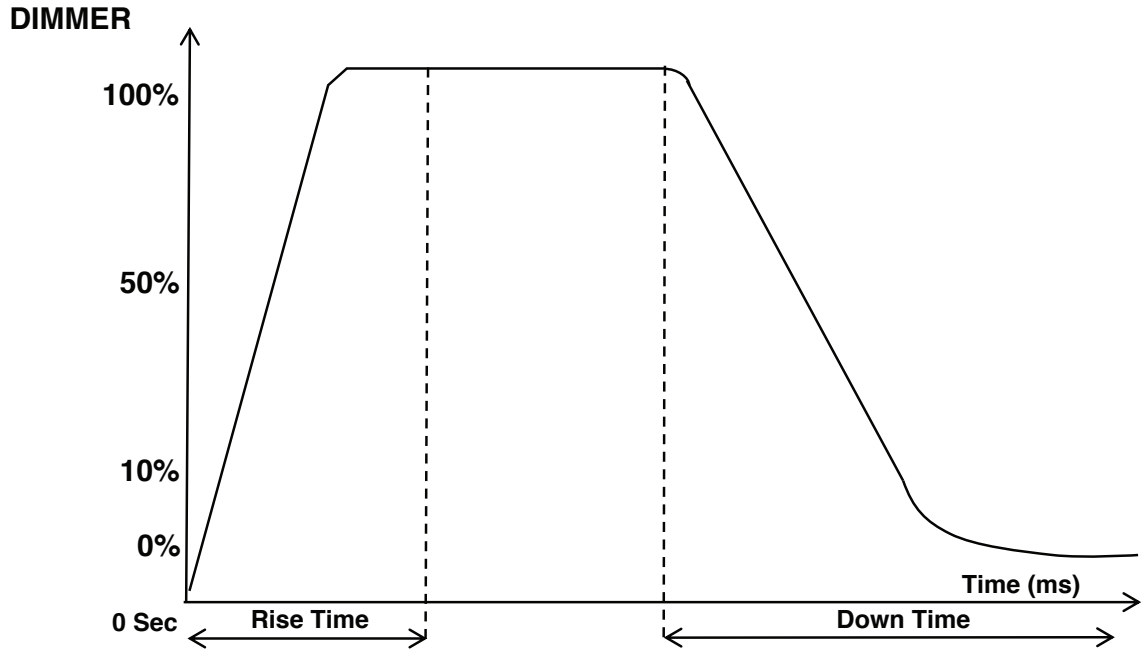

Dimming Curve Ramp Effect	0 sec Fade Time		1 sec Fade Time	
	Rise Time (ms)	Down Time (ms)	Rise Time (ms)	Down Time (ms)
Standard (default)	0	0	0	0
Stage	780	1100	1540	1660
TV	1180	1520	1860	1940
Architectural	1380	1730	2040	2120
Theatre	1580	1940	2230	2280

# PRIMARY-SECONDARY SET UP

This function allows you to link units together to run in a Primary-Secondary set-up, in which one unit will act as the controlling unit and the others will react to the controlling unit's built-in programs. Any unit can be configured to act as a Primary or as a Secondary, but only one unit in a given system can be programmed to act as the Primary.

## ***Primary-Secondary Connections and Settings:***

1. Daisy chain your units via the XLR connectors on the rear panels of each unit. Use standard XLR data cables to link your units together. Remember that the male XLR connector is the input and the female XLR connector is the output. The first unit in the chain (primary) will use the female XLR connector only. The last unit in the chain will use the male XLR connector only.
2. On the units that you want to designate as secondaries, use the display screen and control panel to navigate to Secondary, and press the ENTER button to confirm. The device is now configured as secondary unit which will follow the behavior of the primary unit.
3. The primary unit simply needs to be set to operate as desired, in the same way that the unit would be set up when operating in standalone mode. No additional action is required.

## ***NOTES:***

- Only one unit should be configured as the primary, while all the other units should be configured as secondaries.
- All units should be set to the same DMX channel mode.
- If fixtures fail to sync, verify that all settings mentioned above are the same, then power all devices off, then switch them on again to re-establish the link.

# MULTI UNIT POWER LINKING

This feature allows you to connect the fixtures to one another using the power cable input and output sockets.

**The maximum number of units that can be linked in this manner is as follows:**

- 57 units when running on 120V power.
- 95 units when running on 230V power.

***DO NOT EXCEED THIS MAXIMUM NUMBER WHEN POWER LINKING UNITS!***

All linked units must be of the same make and model type. Do not mix and match units!

# MAINTENANCE GUIDELINES



**DISCONNECT POWER BEFORE PERFORMING ANY MAINTENANCE!**

## **CLEANING**

Frequent cleaning is recommended to ensure proper function, optimized light output, and an extended life. The frequency of cleaning depends on the environment in which the fixture operates: damp, smoky, or particularly dirty environments can cause greater accumulation of dirt on the fixture's optics. Clean the external lens surface regularly with a soft cloth to avoid dirt/debris accumulation.

**NEVER** use alcohol, solvents, or ammonia-based cleaners.

## **MAINTENANCE**

Regular inspections are recommended to ensure proper function and extended life. There are no user serviceable parts inside this fixture. Please refer all other service issues to an authorized ADJ service technician. Should you need any spare parts, please order genuine parts from your local ADJ dealer.

Please refer to the following points during routine inspections:

- A. A detailed electrical check by an approved electrical engineer every three months, to make sure the circuit contacts are in good condition and prevent overheating.
- B. Be sure all screws and fasteners are securely tightened at all times. Loose screws may fall out during normal operation, resulting in damage or injury as larger parts could fall.
- C. Check for any deformations on the housing, color lenses, rigging hardware, and rigging points (ceiling, suspension, trussing). Deformations in the housing could allow for dust to enter into the fixture. Damaged rigging points or unsecured rigging could cause the fixture to fall and seriously injure a person(s).
- D. Electric power supply cables must not show any damage, material fatigue, or sediments.

**NEVER** remove the ground prong from the power cable.

# DIMENSIONAL DRAWINGS

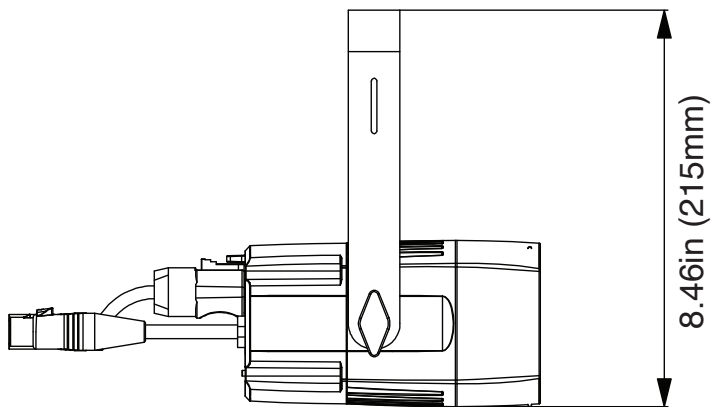
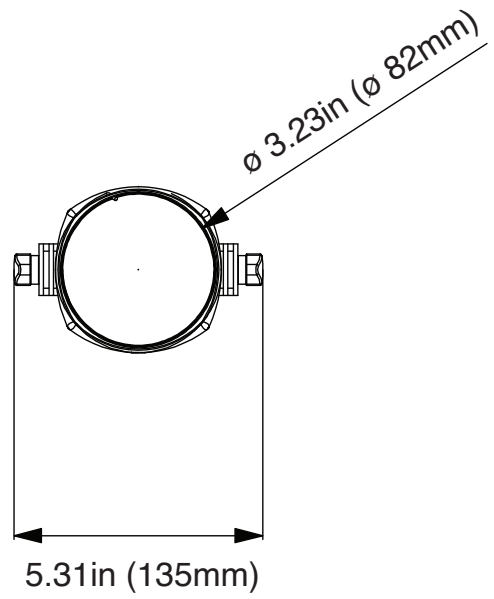
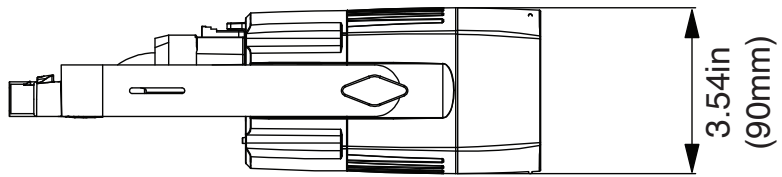
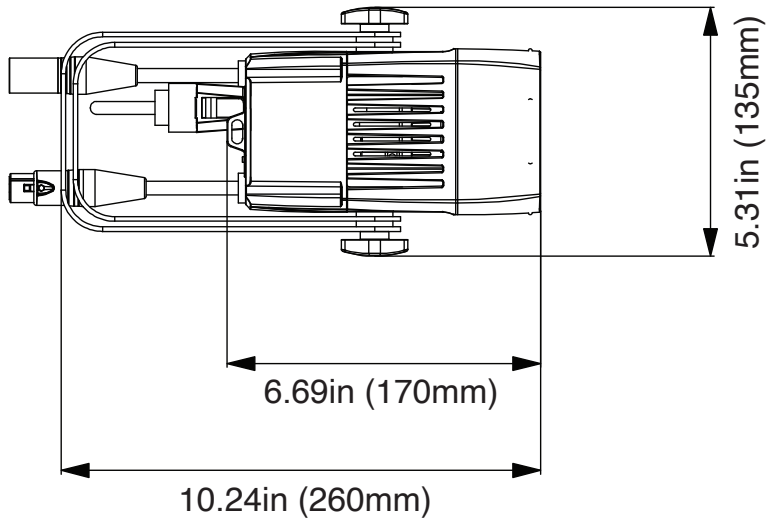

# SPECIFICATIONS

## Optical:

- Light Source: 20 Watt, RGBL LED
- LED Life Expectancy: 30,000 Hrs
- Beam Angle: 5.7°
- Includes 2 interchangeable frost filter lens (10-degree & 45-degree)
- LED Refresh Rate: 3.6KHz

## Technical Features:

- DMX and RDM Compliant
- Color Temperature Presets
- 63 Built-in Color Macros
- 13 Built-in Color Changing Programs
- 4-button Digital Display for easy navigation
- Electronic Dimming 0 – 100%
- Includes a scissor yoke to be hung, or set on the ground

## Connections:

- Power Input: Indoor power locking
- Power Pass through: Indoor power locking
- Control: 5-pin DMX In/Out pigtailed
- With Wired Digital Communication Network

## Control:

- 12 DMX Channel Modes: 3 HSI/4 RGBL/4 HSI+/5 RGBL/6 sRGBLI/6 RGBL/7 RGBL/8 RGBL/8 16bit/10 HSI/12 sRGBLI/13 RGBL
- RDM Compliant

## Electrical:

- Input Voltage: 100-240V 50Hz/60Hz (Auto Sensing)
- Power draw 120V 60Hz: 16.7W, 0.243 Amps
- Power draw 230V 50Hz: 16.7W, 0.147 Amps
- Power Output Current: 1.2A (14W)
- Power Linking: 57pcs @120V, 95pcs @230V

## Physical:

- Dimensions (LxWxH): 6.69" x 5.31" x 8.46" (170 x 135 x 215mm)
- Weight: 3.2 lbs / 1.45 kg.
- Black Housing

## Certifications & Ratings:

- CE
- ETL (Pending)
- IP20



*Please Note: Specifications and improvements in the design of this unit and this manual are subject to change without any prior written notice.*

